



Leading the Ocean & Beyond

ME, 5 years maintenance program

ME-C, ME-B

stx Heavy Industries



ME 5 years maintenance (Specialize for HPS, HCU)

- I. Overhaul interval of ME components**
- II. Overhaul strategy**
- III. Service items**
 - Supply scope**
 - Service scheme**

I . Overhaul interval of ME components

[In accordance with the latest SL2019-681/SRJ]

- ME-C engine ; extracted the category of service and focus on maintenance of HPS, HCU.
- Others are to be followed and nominated the work scope of dock solutions guidance for overhaul SL2019-681.

ME/ME-C engines (diesel and HFO) Guiding overhaul intervals and expected service life

Component	Overhaul interval (hours)	Expected service life (hours)	Remarks
Main hydraulic pump	48,000	96,000	Check and replace hydrostatic bearings at overhaul. Check and replace cylinder set and piston if required.
Proportional valve for main hydraulic pump		32,000	Replace
Hydraulic start-up Pump		96,000	
Coupling/spider	6,000		Condition based replacement.
Bearings	32,000	32,000	Replace bearings.
Pressure relief valve for main hydraulic pumps	48,000	96,000	Replace sealings at overhaul.
FIVA	32,000	64,000	Check and replace if required. Replace pilot valve after 32,000 hours.
ELVA	32,000	64,000	Check and replace if required. Replace pilot valve after 32,000 hours.
ELFI	32,000	64,000	Check and replace if required. Replace pilot valve after 32,000 hours.
PEVA	32,000	64,000	Check and replace if required. Replace pilot valve after 32,000 hours.

I . Overhaul interval of ME components

[In accordance with the latest SL2019-681/SRJ]

ME/ME-C engines (diesel and HFO) Guiding overhaul intervals and expected service life

Component	Overhaul interval (hours)	Expected service life (hours)	Remarks
Cylinder lubricator	3,000	96,000	Check non-return valve and replace it if leaking. Overhaul at an authorised MAN Energy Solutions workshop.
	32,000		
Exhaust actuator	24,000	64,000	Lifetime can deviate due to cavitation.
Non-return valve		12,000	Replace after 12,000 hours.
Fuel oil pressure booster	32,000	64,000	Change sealing rings on hydraulic piston and suction valve at overhaul.
	based on engine observations	replace or recondition	
Suction valve	8,000	16,000	Check for wear at seat and conical ring.
Accumulators on HPS and HCU	N ₂ pressure	2,000	Engine lifetime
	Rubber diaphragms	32,000	
Hydraulic safety block			Check and adjust safety valve if required after 32,000 hrs.
Cartridge valves	Change O-rings	32,000	
Solenoid valve		96,000	
Hydraulic hoses		32,000	Replace after 5 years.
Starting valve	16,000	96,000	Replace parts if required.
Pilot valve	32,000	64,000	

I . Overhaul interval of ME components

[In accordance with the latest SL2019-681/SRJ]

- ME-B engine ; extracted the category of service for HPS, HCU.
- Others are to be followed and nominated the work scope of dock solutions guidance for overhaul SL2019-681.

ME-B engines (diesel and HFO) Guiding overhaul intervals and expected service life

Component	Overhaul interval (hours)	Expected service life (hours)	Remarks
Main hydraulic pump	48,000	96,000	Check and replace hydrostatic bearings at overhaul. Check and replace cylinder set and piston if required.
Proportional valve for main hydraulic pump		32,000	Replace
Hydraulic pump Coupling/spider	6,000	96,000	Condition-based replacement.
Pressure relief valve for main hydraulic pumps	48,000	96,000	Replace sealings at overhaul.
Exhaust actuator	32,000	96,000	
ELFI valve	32,000	64,000	Check and replace if required. Replace pilot valve after 32.000 hours.
Fuel oil pressure booster	32,000	64,000	Change sealing rings on hydraulic piston and suction valve at overhaul.
Suction valve	based on engine observations 8,000	replace or recondition 16,000	Check for wear at seat and conical ring.
Cylinder lubricator	3,000 32,000	96,000	Check non-return valve and replace it if leaking. Overhaul at an authorised MAN Energy Solutions workshop.
Accumulators on HPS and HCU	N ₂ pressure Rubber diaphragms 2,000 32,000	Engine lifetime	Replace diaphragms after 5 years.
Hydraulic safety block			
Cartridge valves	Change O-rings 32,000	96,000	Check and adjust safety valve if required after 32,000 hrs.
Solenoid valve		64,000	
Hydraulic hoses		32,000	Replace after 5 years.

[In accordance with service experience and the latest overhaul guidance]

- The overhaul strategy made to bring out the reliable operation to our valuable customer based on over 10 years service experience of ME engine which accumulated expertise from in service. The detail service plan with relevant spare parts will be listed up according to the PJT information.

1) Hydraulic Power Supply (HPS)

a) ME-B

- Electric motor (bearing) : 32,000 hrs (replacement)
- Hyd' pump : 48,000 hrs (overhaul)
- Safety accumulator block : 32,000 hrs (changed the O-ring)

b) ME-C

- Start up pump (Bearing) : 32,000 hrs, for the claw coupling (spider) to be replaced with condition based
- Hyd' pump : 48,000 hrs (overhaul-reconditioned)
- Safety accumulator block : 32,000 hrs (changed the O-ring)
- Control valve : 32,000 hrs (replacement)
- Hyd' hose : 32,000 hrs (replacement)

2) Hydraulic Cylinder Unit (HCU)

a) Fuel oil pressure booster : 32,000 hrs (overhaul)

- Suction valve : 16,000 hrs (replacement), 8,000 hrs (overhaul)

b) Exh' actuator : 24,000 hrs (overhaul, ME-C) / 32,000 hrs (overhaul, ME-B)

- Non return valve for actuator inlet : 12,000 hrs (replacement)

3) Hydraulic control valves

- FIVA and HPS pump : 32,000 hrs (Replacement)

[In accordance with service experience and the latest overhaul guidance]

4) Accumulator

- Recharge N2 : Minimum once a month
- Membrane : 32,000 hrs (replacement)

5) Hydraulic oil cleanliness

- After oil filter : ISO4406 XX/16/13 (Compulsory for optimum lifetime of ME components)
- Build up time / Decay time measurement
- SFF (Super Fine Filter) application for oil cleanliness control

6) Pneumatic system

- Replaced the repair kit for valves then function test of pneumatic system

7) Electric system, equipment

- Check the pressure transmitter, sensor and level sensor
- Examination a cable connection / Check the insulation
- MPC, MPC10, junction box
- O.M.D / P.C.O / A.V.M / Cylinder L.O heating tank
- Auto filter
- Function test for interlock system

8) Confirmation trial

- Function test of HCU, HPS, Tacho system
- Conduction confirmation trial in order to evaluate a overhaul and restoration

III. Service Items

[Supply scope of spares]

2) HPS (Hydraulic Power Supply)

- ME-C

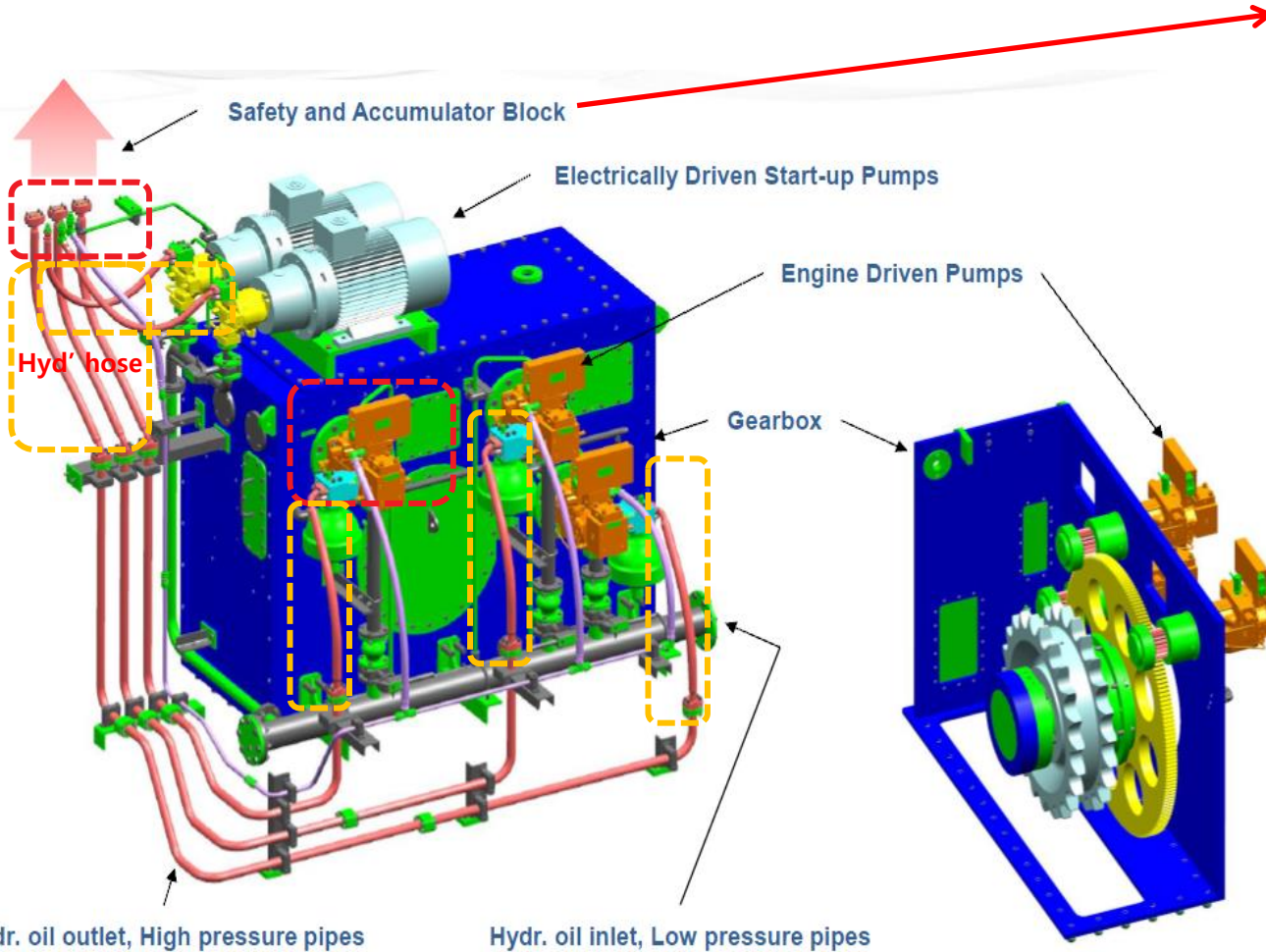

After overhaul the components, Evaluation of condition to be verified then relevant items to be replaced.

- a) Hyd' pump (*For detail info. next page)
 - Reconditioned (Option)
 - Replacement by new pump (Option)
- b) Hyd' hose
 - Hydraulic hoses on HPS
 - Adaptor
- c) Accumulator block
 - Pos.310, 311 valve (cartridge valve)

III. Service Items

[Supply scope of spares]

2) HPS (Hydraulic Power Supply)

- ME-C

- a) HPS pump overhaul strategy ;
 - Reconditioned (Option) – Red + Blue
 - Replacement the pump (Option)

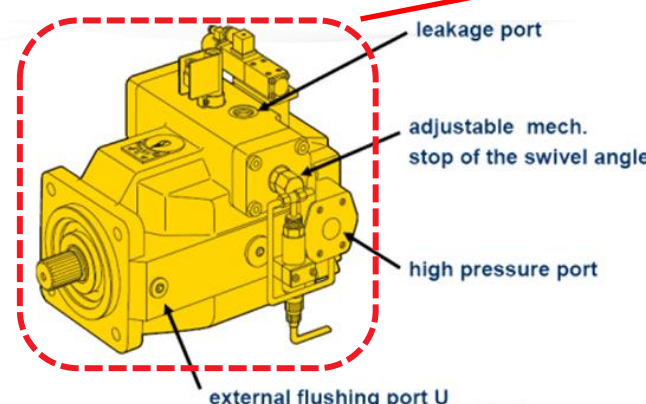
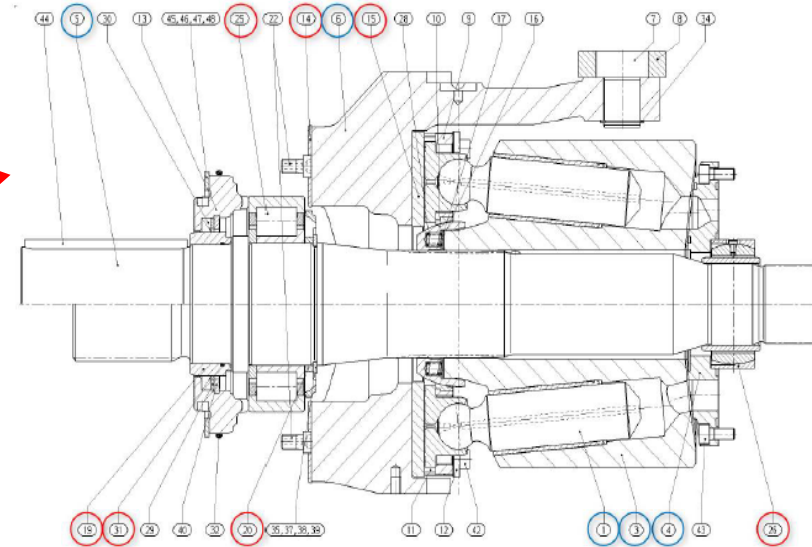

Variable displacement pump
A4VSO – HS3 control

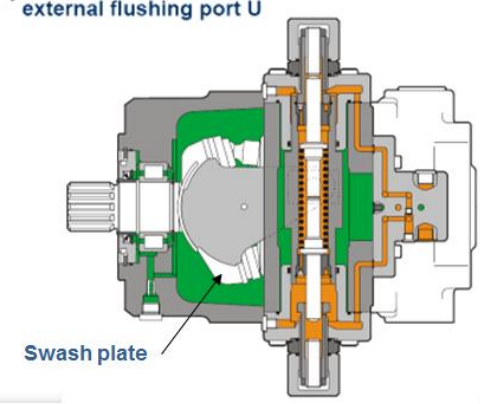
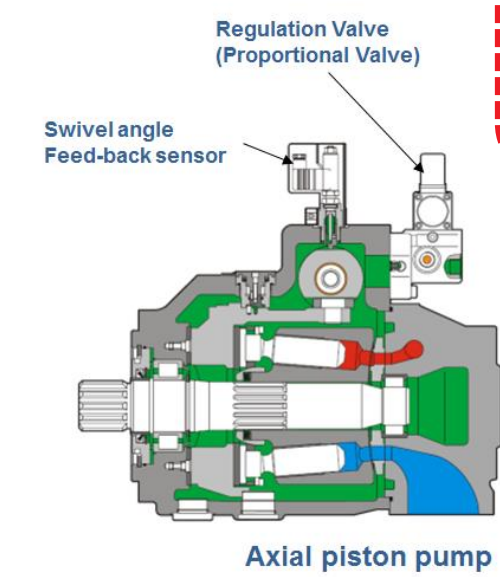

Item	Description	Unit	Q'ty	Number	Remark
1)	SEAL BUSH	EA	1	19	Basic replacement items
2)	PLAIN ROLLER BEARING	EA	1	25	Basic replacement items
3)	SLIPPER DISC	EA	1	15	Basic replacement items
4)	BEARING-LINER	EA	2	14	Basic replacement items
5)	SLIDE BEARING	EA	1	26	Basic replacement items
6)	O-RING	EA	1	31	Basic replacement items
7)	FRONT WHEEL	EA	1	20	Basic replacement items
8)	PISTON-SLIPPER PAD	EA	9	1	Optional replacement items
9)	CYLINDER WITH BUSH	EA	1	3	Optional replacement items
10)	CONTROL PLATE	EA	1	4	Optional replacement items
11)	DRIVE SHAFT	EA	1	5	Optional replacement items
12)	SWASHPLATE	EA	1	6	Optional replacement items

III. Service Items

[Supply scope of spares]

2) HPS (Hydraulic Power Supply)

- ME-B

* The detail list of spare for dock service to be submitted in accordance with actual PJT application of ME system.

After overhaul the components, Evaluation of condition to be verified then relevant items to be replaced.

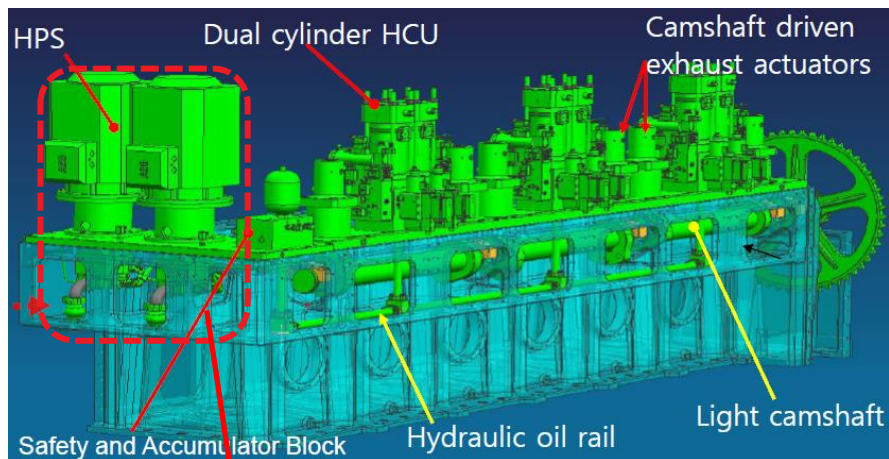

- a) Electrically controlled motor
- Bearing
- b) Hyd' pump (Option)
- Replacement by new pump
- c) Claw coupling – Spider
- d) Accumulator block
- Pos.213, 311, 212 valve
- Proportional valve

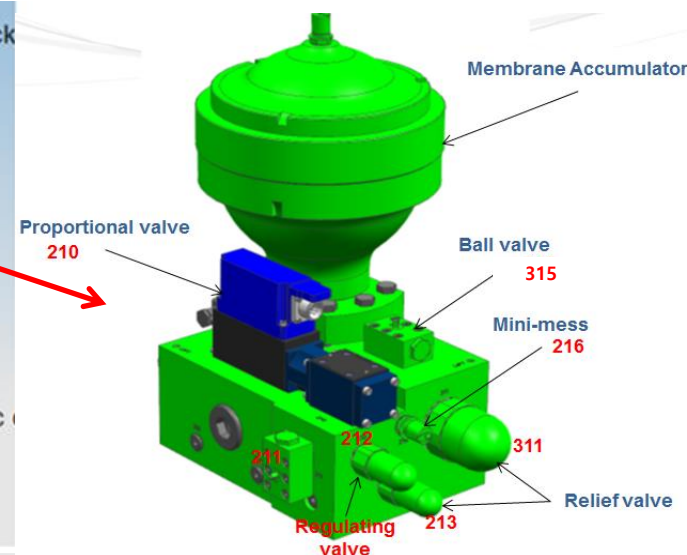
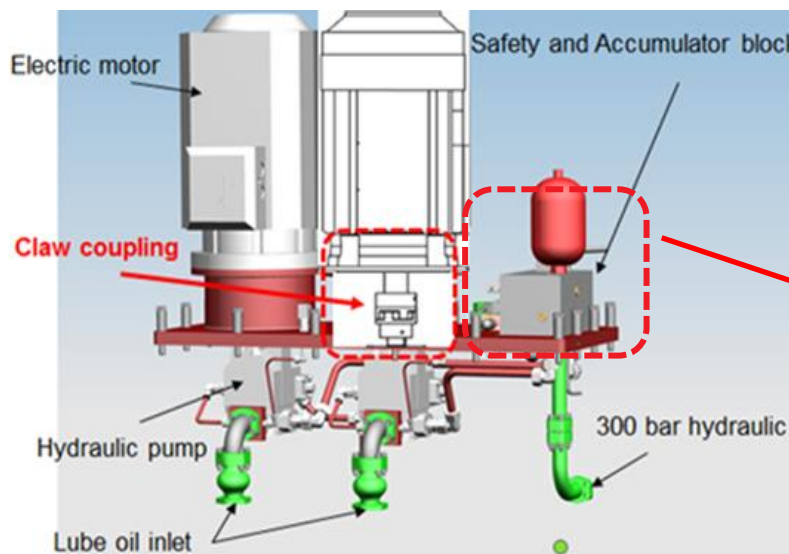
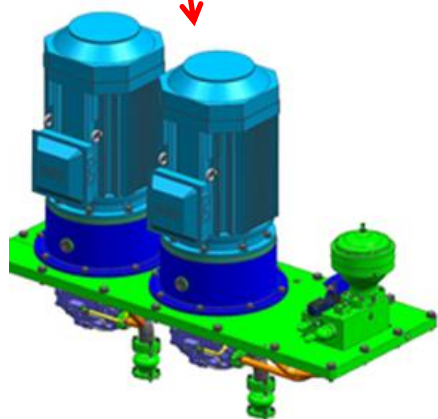

[Supply scope of spares]

- The items are nominated based on overhaul guidance and maintenance of the latest recommendation of MDT.
- This presentation is reference as subject to overhaul / inspection scope of ME components. The details spare parts list to be submitted separately in accordance with actual PJT information.

3) HCU (Hydraulic Cylinder Unit)

After overhaul the components, evaluation of condition to be verified then relevant items to be replaced.

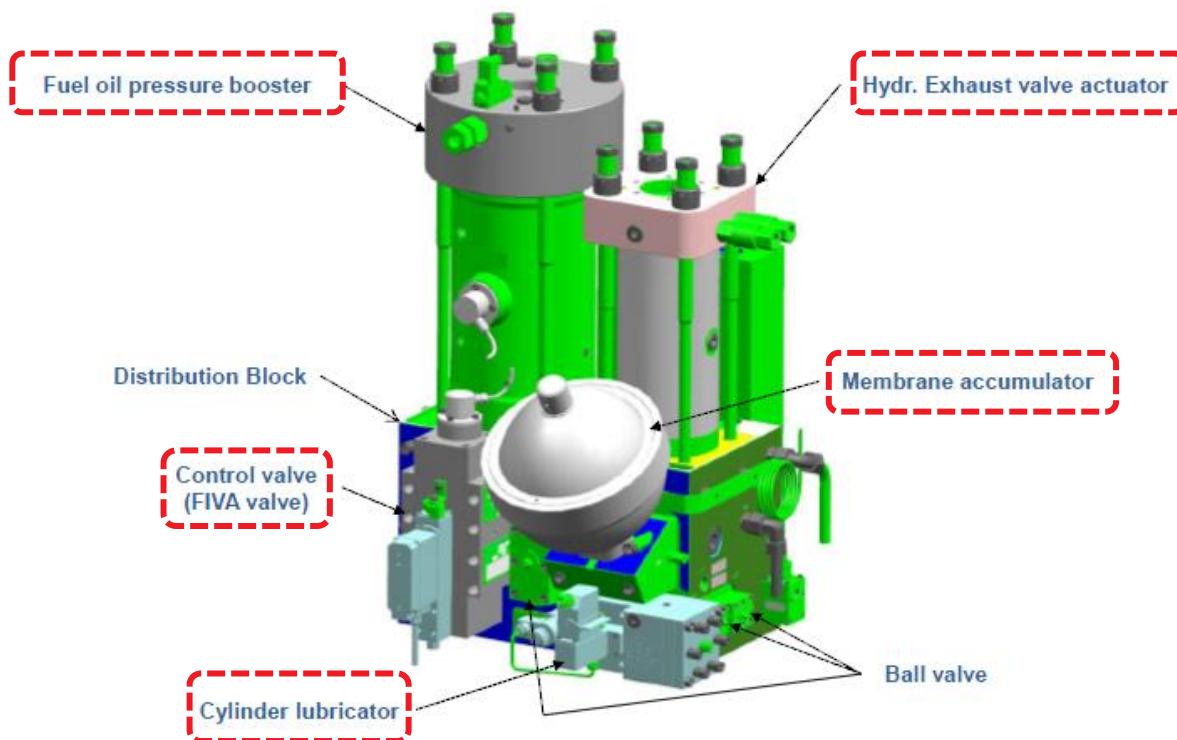

- a) Fuel oil pressure booster
 - Square sealing ring
- b) Exhaust valve actuator (No application ME-B)
 - Square sealing ring
- c) FIVA valve
 - Control valve
 - Including repair kit (sealing ring)
- d) Cylinder lubricator
 - Sealing ring, Solenoid valve, NRV, Plunger (option)

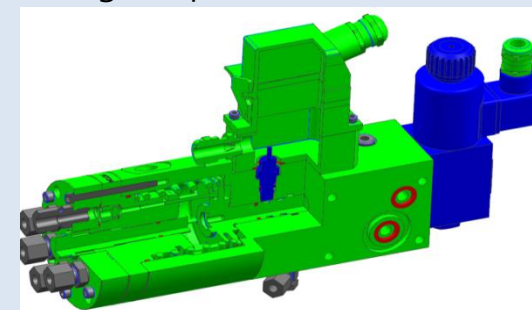

- e) Accumulator
 - Membrane

III. Service Items

[Supply scope of spares]

3) HCU (Hydraulic Cylinder Unit)

The detail information for repair kit for HCU. For the Exh' actuator is specified only ME-C engine.
Basically, the repair kit is consist of square sealing ring, O-ring and NRV (actuator) & suction valve, throttle valve (F.O booster).

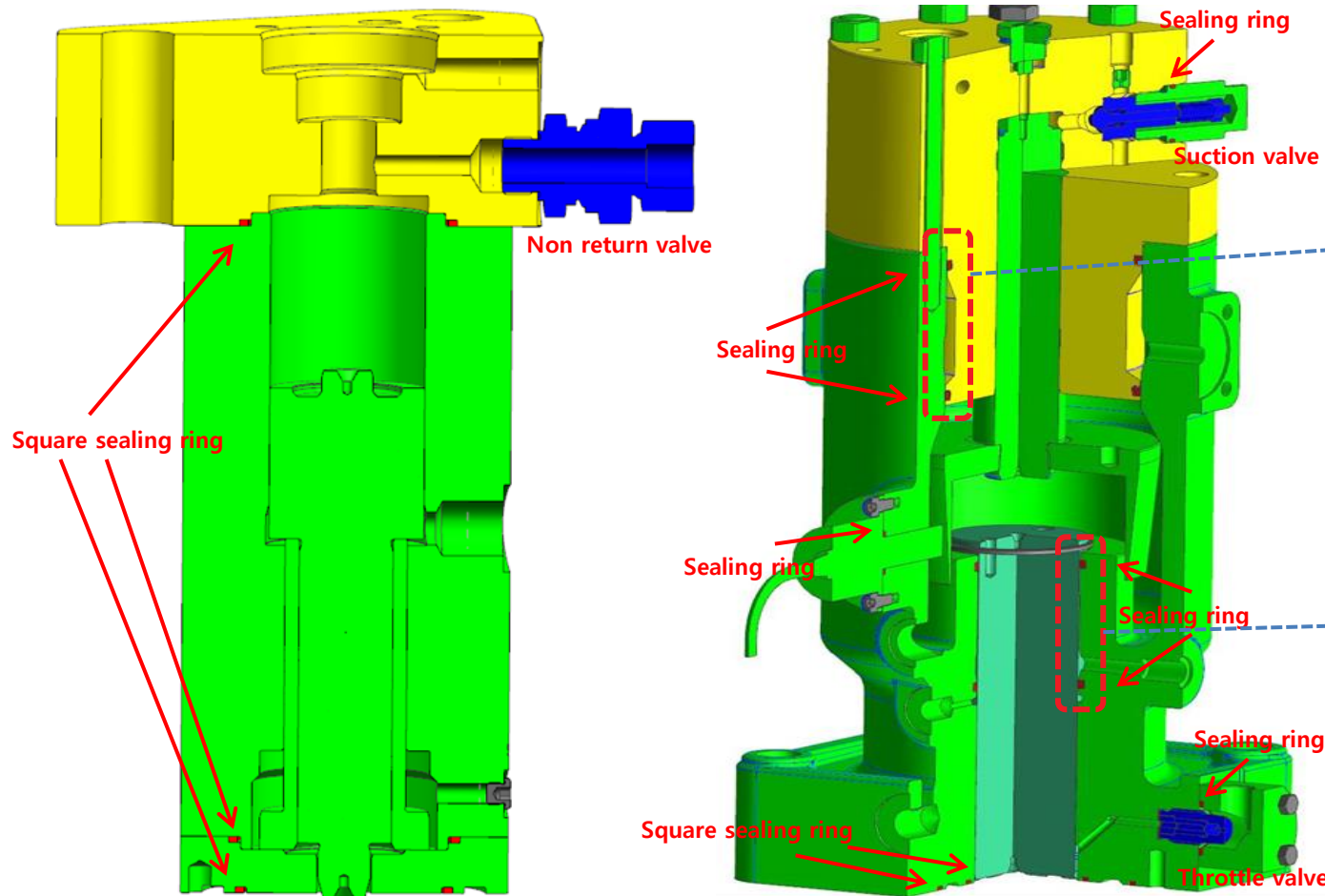

#) For prevention oil deterioration, pay attention for assembly direction of fuel booster.

Technical drawings showing assembly details of the fuel booster, including a red dashed box highlighting a specific area.

[Supply scope of spares]

4) Hydraulic Control valve (FIVA)

The FIVA valve (MDT, Nabtesco, Bosch Rexroth, Curtiss Wright) is compatible with each maker after application proper parameter as specified profile of fuel injection and exh' vv open/close timing.

The on board retrofit is carried out ;

- Overhaul the all components then exchange sealing ring
- Replacement of 4/3way proportional valve
- After reassembly, carry out the function test
- In case of exchange the inductive sensor, calibration to be required

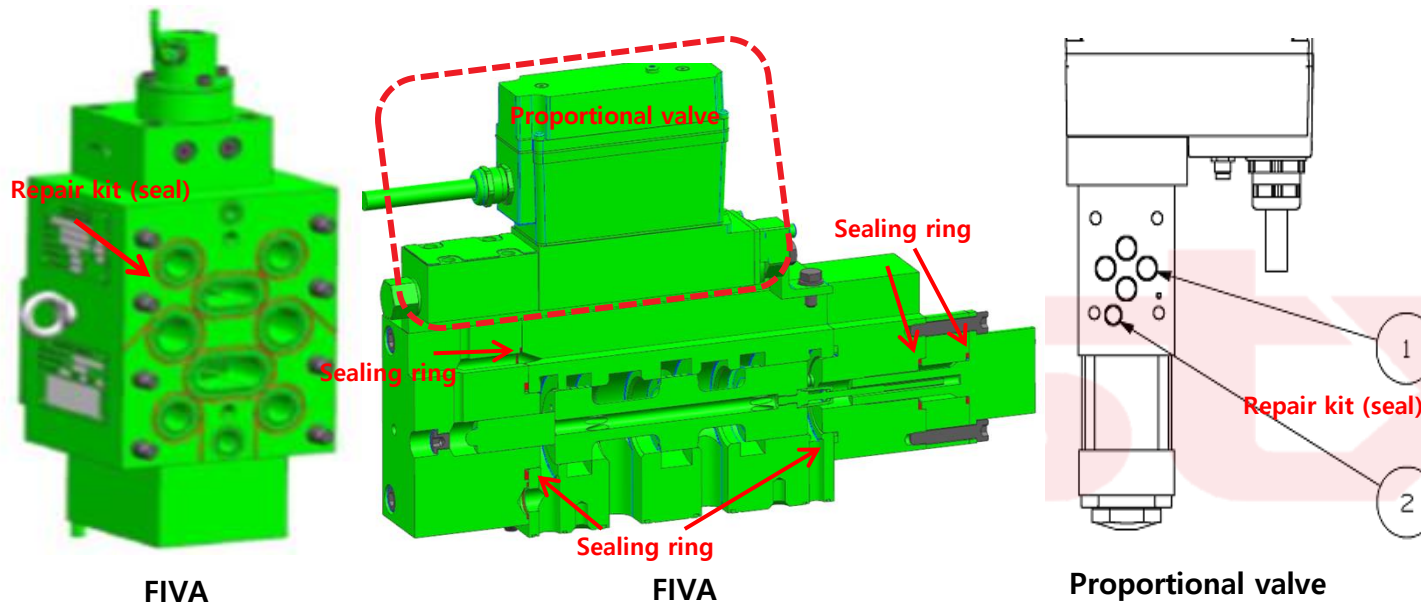

- a) FIVA repair kit, seal (where mating surface into HCU)
- b) FIVA repair kit, seal (internal assembly sealing)
- c) Proportional repair kit, seal (where mating surface to FIVA)
- d) 4/3way proportional valve

[Supply scope of spares]

5) Accumulator (HCU, HPS)

Based on the service experience incorreceted N2 pressure can be made improper injection timing and exhaust valve open/close in HCU or Hyd' pressure unstable fluctuation in HPS.

The periodically recharging of N2 to be carried out based on the inspection result which for measured at least once a month. The on board retrofit is carried out ;

- . Overhaul the all accumulator then exchange diaphragm
- . After reassembly, refill the N2
- . Carry out the leakage test and measurement of prospect pressure in accordance with ambient temperature

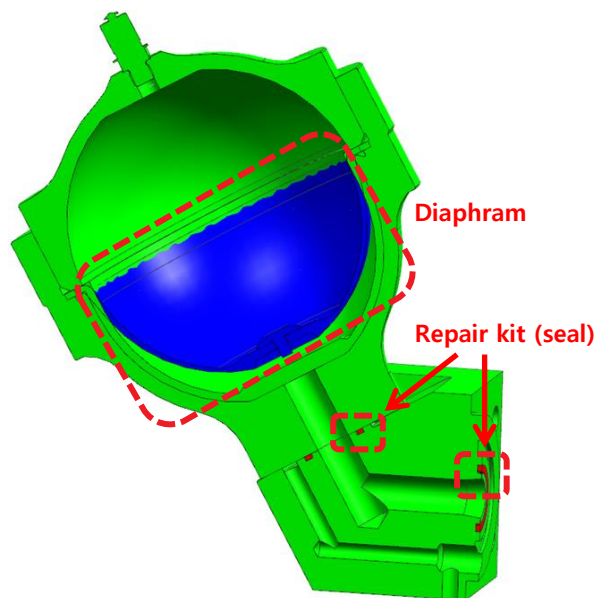

a) Accumulator repair kit
 -. Diaphragm
 -. Sealing

Accumulator temp' (°C)	0°C	10°C	20°C	30°C	40°C	50°C	60°C	70°C	80°C	90°C	100°C
Pressure (bar)	124	130	136	142	148	154	160	166	172	178	185

Pressure adjustment table (300 bar HPS system)

[Supply scope of service]

6) Hydraulic Oil Cleanliness

For optimum lifetime of ME components and liable operation, the hydraulic oil cleanliness should be met grade of ISO4406 XX/16/13. **(for optimal control of cleanliness L.O, the Super Fine Filter maintenance to be recommended.)**

The reference method for evaluation as condition-based monitoring system, the pump build up time until 225 bar pressure to be measured.

- ME-C : Only one electric pump to be required build up time within 3 min.
Both pumps to be required build up time within 1.5 min
- ME-B : Decay time (depressurize time from 220 bar to 160 bar) displayed by MOP when HPS system turn off

Lubricating oil system for an ME engine

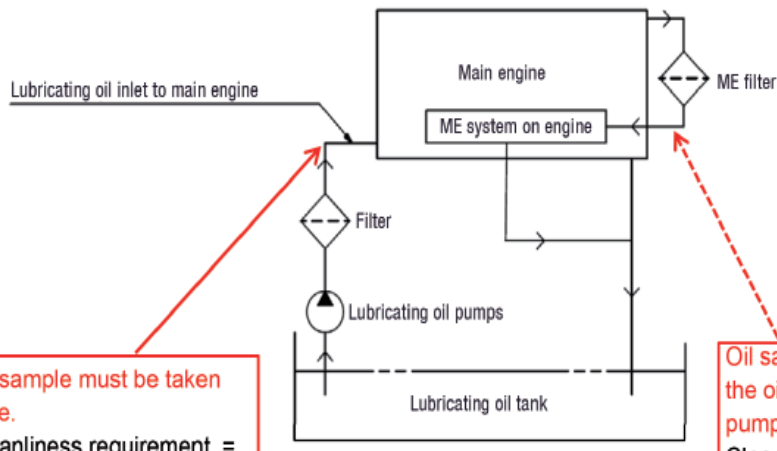

Oil sample must be taken here.
Cleanliness requirement = ISO 4406 xx/19/15

Figure 1

Oil sample must be taken at the oil inlet to the hydraulic pumps.
Cleanliness requirement = ISO 4406 xx/16/13

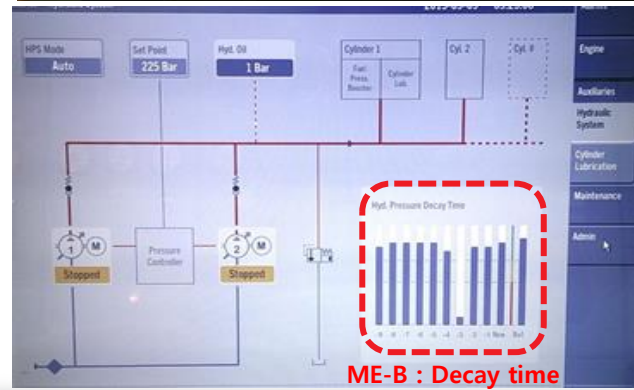
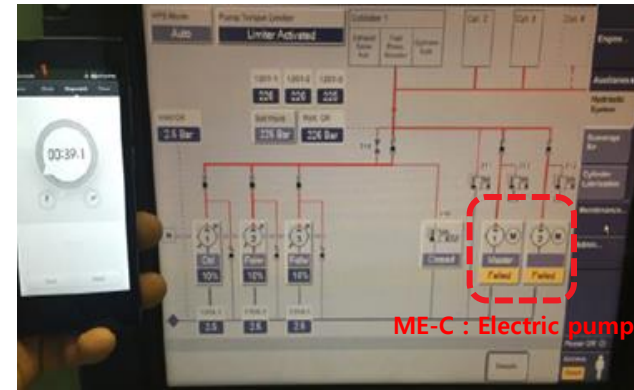

[Supply scope of spares]

7) Pneumatic Control System (ME-C)

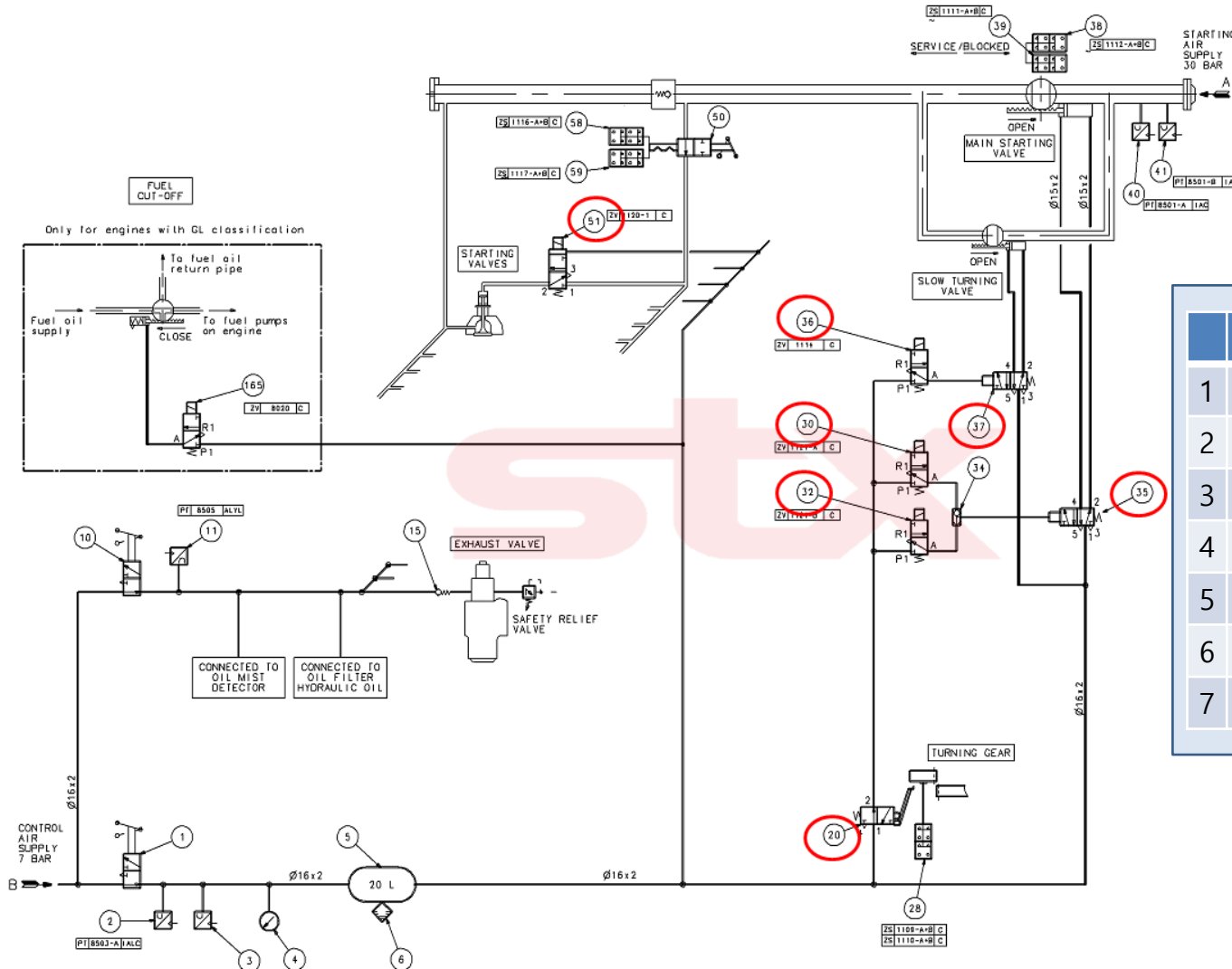

	Pos'	Description
1	20	3/2 way v/v (turning gear)
2	30	3/2way solenoid v/v (slow turn)
3	32	3/2way solenoid v/v (start' air)
4	36	3/2way solenoid v/v (start' air)
5	35	5/2way v/v (main starting)
6	37	5/2way v/v (slow turn)
7	51	3/2 way v/v (Start' air pilot)

III. Service Items

[Supply scope of spares]

7) Pneumatic Control System (ME-B)

	Pos'	Description
1	27	5/2way v/v (main starting)
2	33	3/2 way v/v
3	55,56	3/2 way v/v (Ahead, Astern)
4	57	Repair kit for air cylinder
5	84,86,88	Repair kit for 3/2 way solenoid v/v
6	90	Repair kit for 3/2 way solenoid v/v
7	117	3/2 way v/v (starting air distributor)
8	115	3/2 way v/v (turning gear)
9	118	Shut off valve (v/v to starting air distributor)

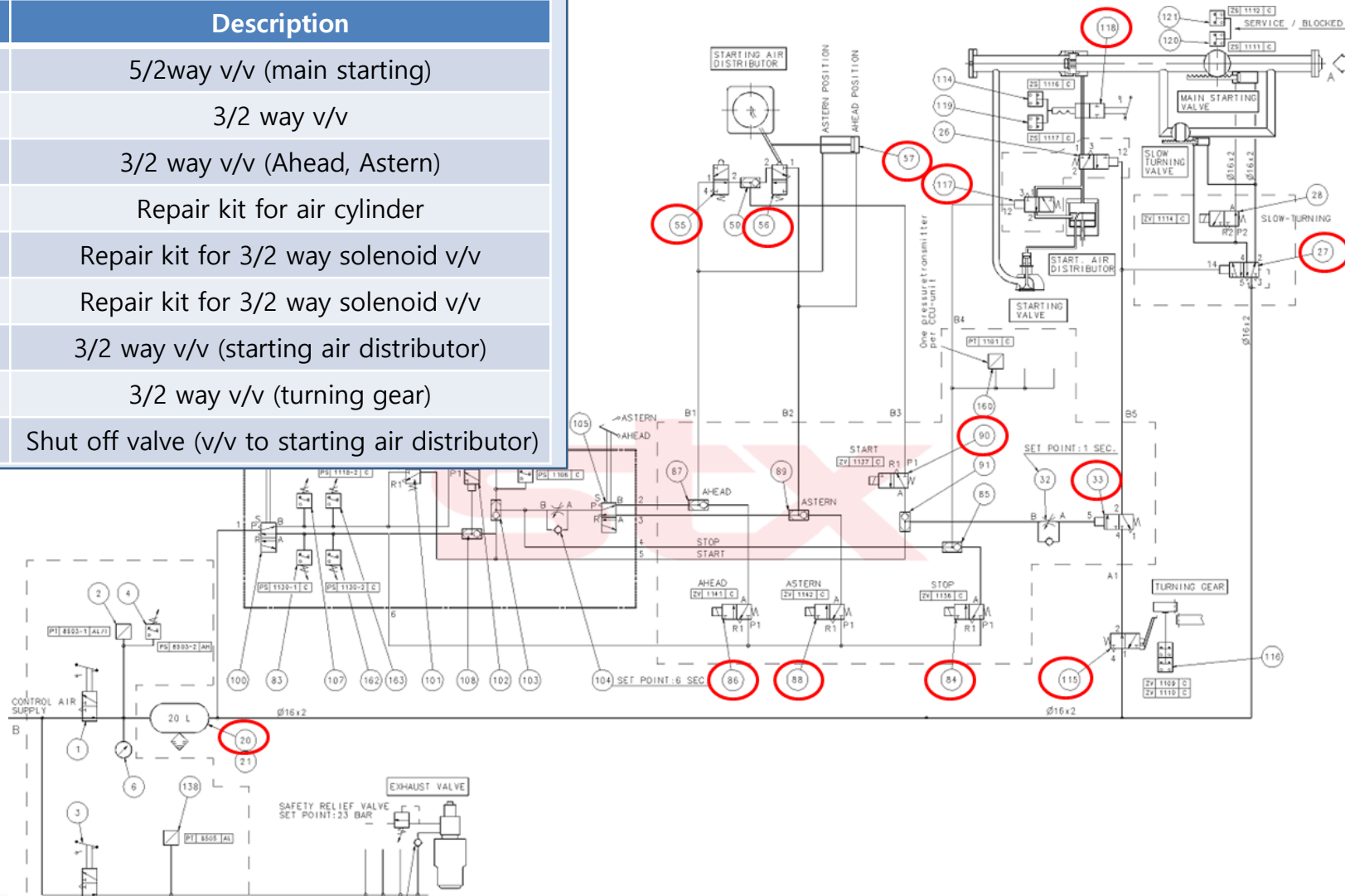

[Service scheme]

8) Electric system, equipment

In order to eliminate electrical noise and low insulation, the cable connection/condition to be checked and rectified in case of found out abnormalities.

Below items to be inspected while dry dock service ;

- Check the pressure transmitter, sensor and level sensor
- Examination a cable connection / junction boxes
- Check the low insulation
- MPC, MPC10, TSA, DAU
- Inductive sensor of HCU
- Power Supply Unit
- PMI, CoCos EDS, Local Operation Panel (LOP)
- O.M.D / P.C.O / A.V.M / Cylinder L.O heating tank
- Auto filter
- Function test for interlock system

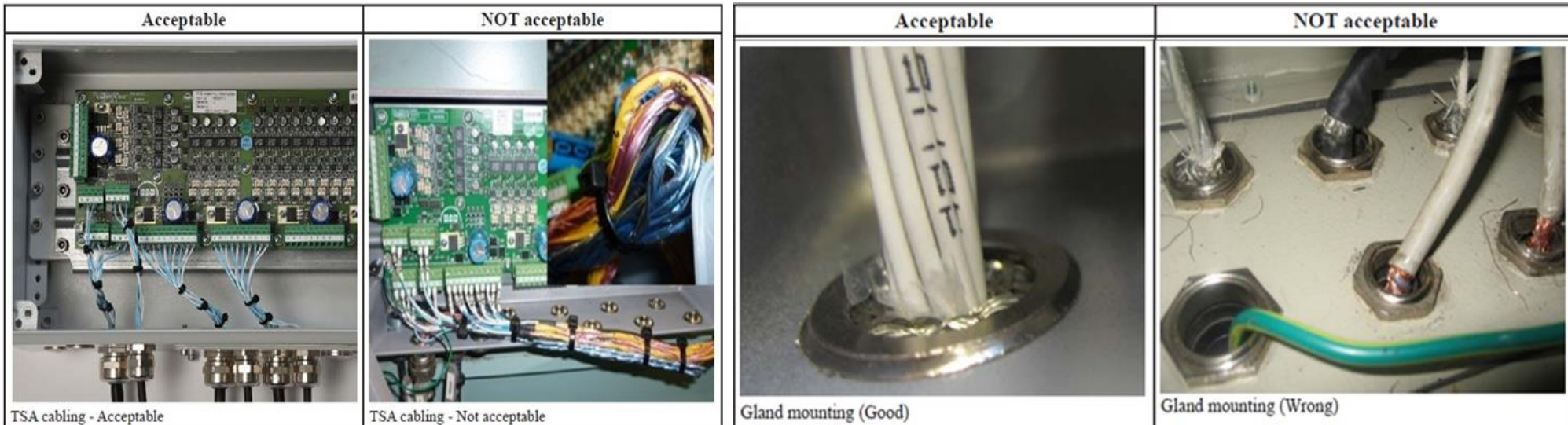

[Service scheme]

9) Confirmation trial

After completion all overhaul inspection and replacement of ME components on HCU and HPS, the confirmation trial to be required in order to evaluate for condition of restoration properly.

During confirmation trial monitoring and adjustment of ME performance will be conducted by qualified service engineer.

- Fuel Quality Adjustment (FQA)
- Cylinder oil feed rate
- Engine performance
- Tacho system : TDC calibration (in case of allowance the load up 50% during confirmation trial)

Service scheme of dry dock repair	Day 1	Day 2	Day 3	Day 4	Day 5	Day 6	Day 7	Day 8
Overhaul/replacement of HCU components	→							
Inspection/replacement of cylinder lubricator, oil level sensor			→					
Overhaul/replacement of HPS components	→							
Replacement of diaphragm and refill of nitrogen gas pressure on all accumulators					→			
Inspection of electric system (MPC, MPC-10, PSU, Junction boxes, etc..)					→			
Function test and calibration of HCU, HPS, Tacho system. Function test of hydraulic leakage, starting air pilot valves						→		
Sea trial (PMI measurement, safety device function test, Engine performance evaluation)								→